



Cartridge Filler CF 100

 **SCHWERDTEL**

- Fully automatic double head cartridge filling and closing unit
- For metal, cardboard and plastic cartridges
- Tool free exchange of product contacted parts
- Perfect and easy adjustment according to product characteristics
- Output: up to 100 cartridges per minute

- 1 Cartridge Infeed
- 2 Cartridge Separating
- 3 Dosing Unit
- 4 Filling Station
- 5 Plunger Inserting Station
- 6 Plunger Control
- 7 Operator Panel
- 8 Turning Station
- 9 Cartridge Discharge
- 10 Plunger Elevator
- 11 Plunger Hopper

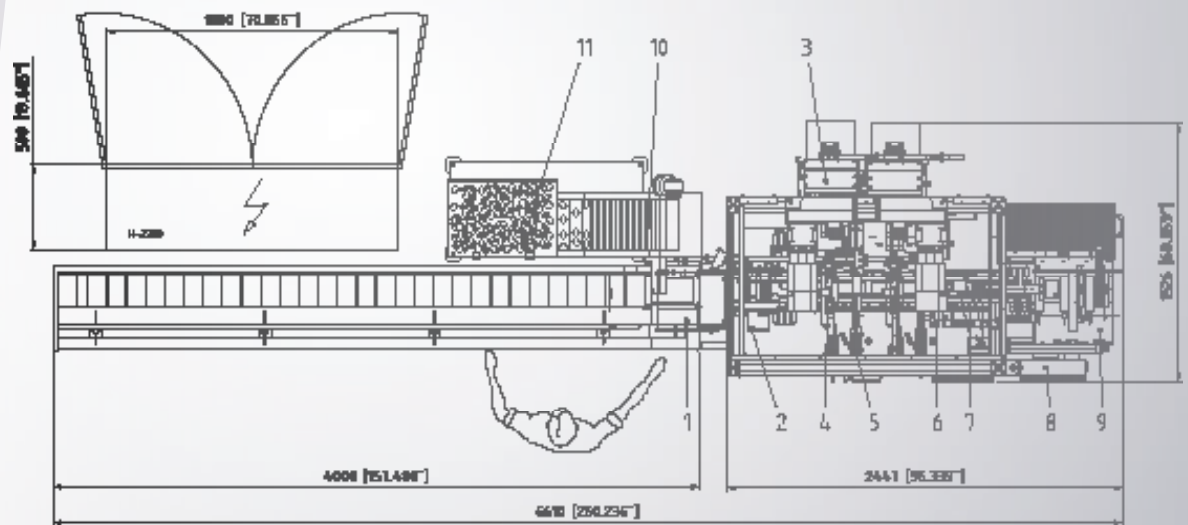

Technical Data

Machine Type

Dimensions (L x W x H) [mm]/[inch]
 Weight [kg]/[lb US]
 Output [cpm]
 Cartridge Type

Automatic Cartridge Filler CF SplitStream

6.610 x 1.526 x 2.148 / 260 x 60 x 84,6
 1.885 / 4,155
 up to 100, depending on product pressure and viscosity
 aluminium, plastic, composit cartridges (310 ml)

Electrical Connections

Voltage
 Power Requirement [kVA]
 Control System
 IP Rating

3 x 400V, 50Hz (or according to local requirements)
 57
 Siemens SPS S7-300
 IP 44

Compressed Air Connections

Air Pressure [bar]/[psi]
 Air Consumption [Nm³h @ 100
 cartridges /minute]

min. 6 / 87
 approx. 80



Ludwig Schwerdtel GmbH · Boschstrasse 8
 D-85757 Karlsfeld near Munich
 Tel: +49 8131 9006-0 · Fax: +49 8131 97211
 info@schwerdtel.de · www.schwerdtel.de