

S 8-V Cartridge Filler

Cartridge Filler

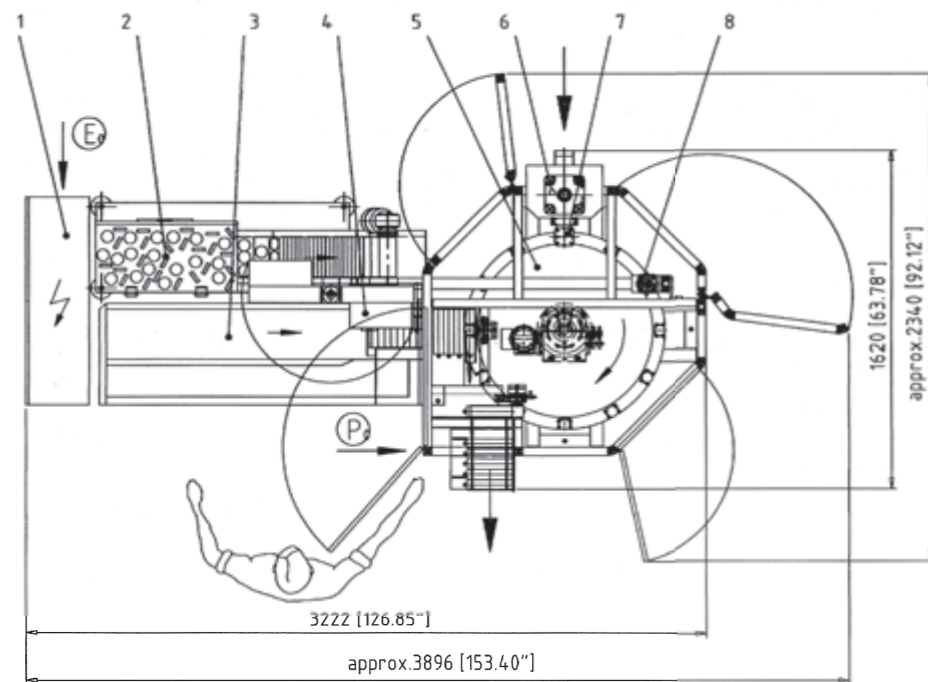

- 1 switch cabinet
- 2 plunger magazine with sorting elevator for approx. 3500 plungers
- 3 cartridge magazine for approx. 400 cartridges
- 4 operating panel
- 5 cartridge transport via turning table
- 6 pneumatically driven dosing cylinder
- 7 filling station
- 8 plunger inserting station

Specifications

type of machine	S 8-V
dimensions (L x W x H)	3220 x 1630 x 2260 mm
weight	1300 kg
output	up to 30 cartridges/min.
drive of the dosing unit	pneumatic
dosing range	260 ml – 340 ml
product inlet	1380 mm
cartridge outlet height	1060 mm
electrical connection	
voltage	3 x 400 V, 50 Hz
power requirement	7,5 kVA
control	Siemens S7 SPS
protection class	IP 44
air connection	
air pressure	6 bar
air consumption	75 Nm ³ /h

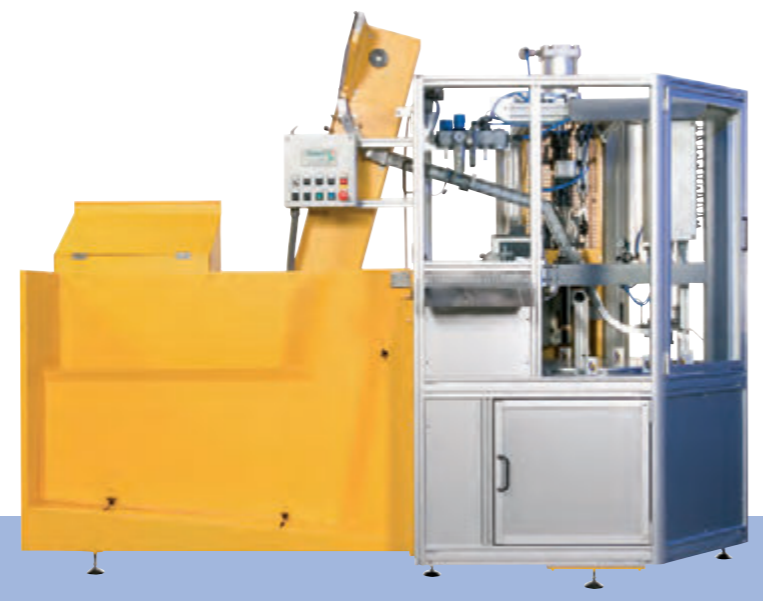

www.renoarde.de

S 8-V

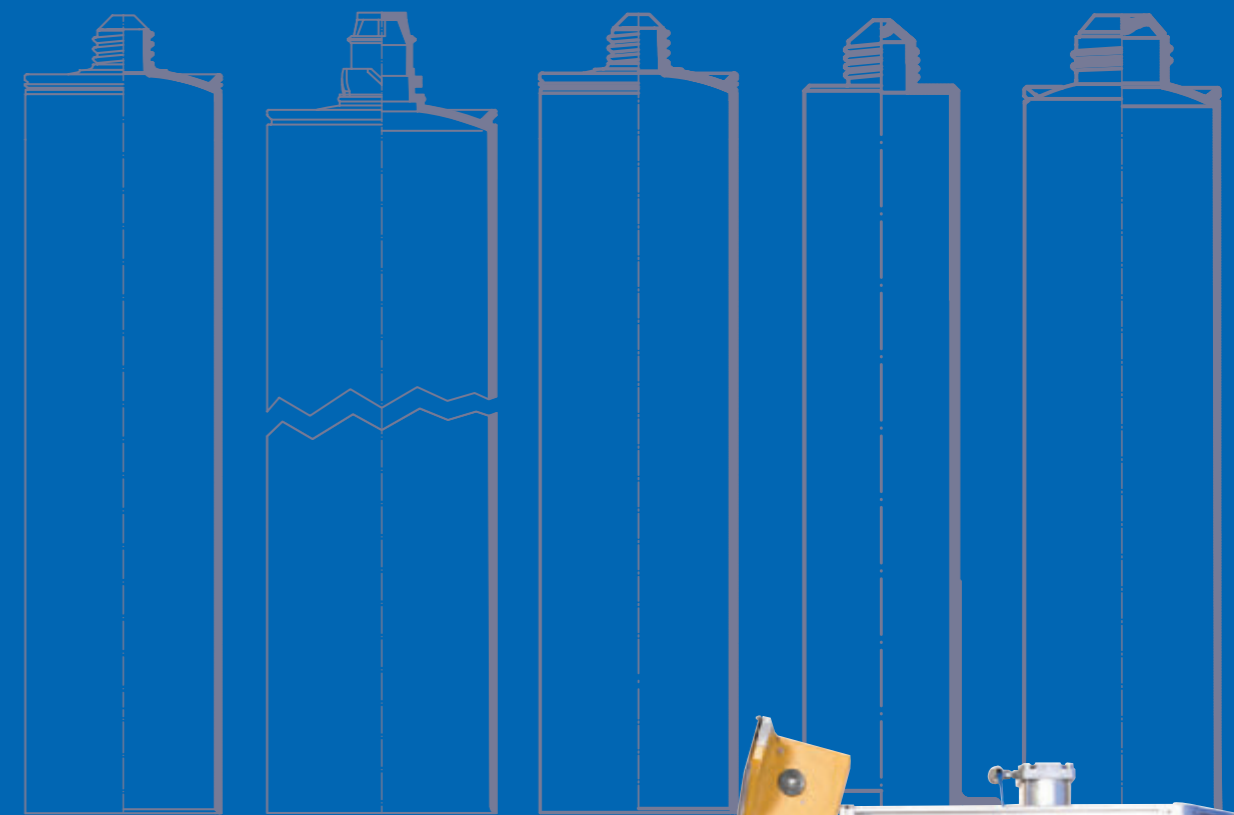

- Feeding
- Dosing
- Mixing
- Filling
- Closing
- Packing



Cartridge Filler S 8-V



The first fully automatic cartridge filler in the world was of course made by Schwerdtel and was a vertical filler with extraordinary quality and reliability. Now more than 35 years of experience and significant further development leave its mark on our new generation of vertical cartridge fillers, which successfully complete our world class range of products.

- vertical filling line for low-viscosity and high-viscosity products
- for plastic, compound and aluminium cartridges
- for single and two-component cartridges
- quickly exchangeable set of product-contacted parts
- flexible upgradeability
- high-precision dosing

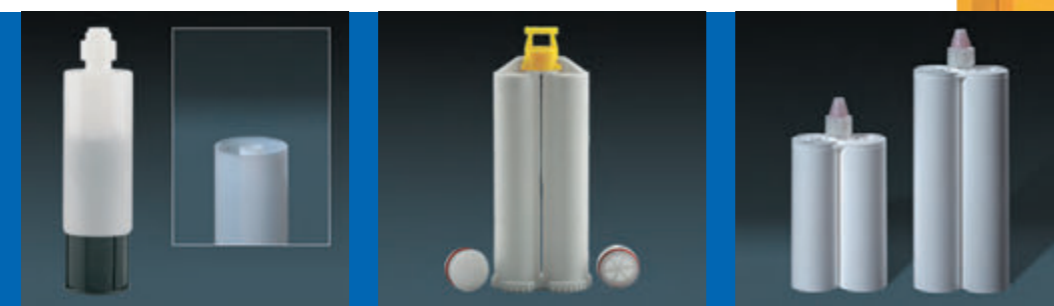
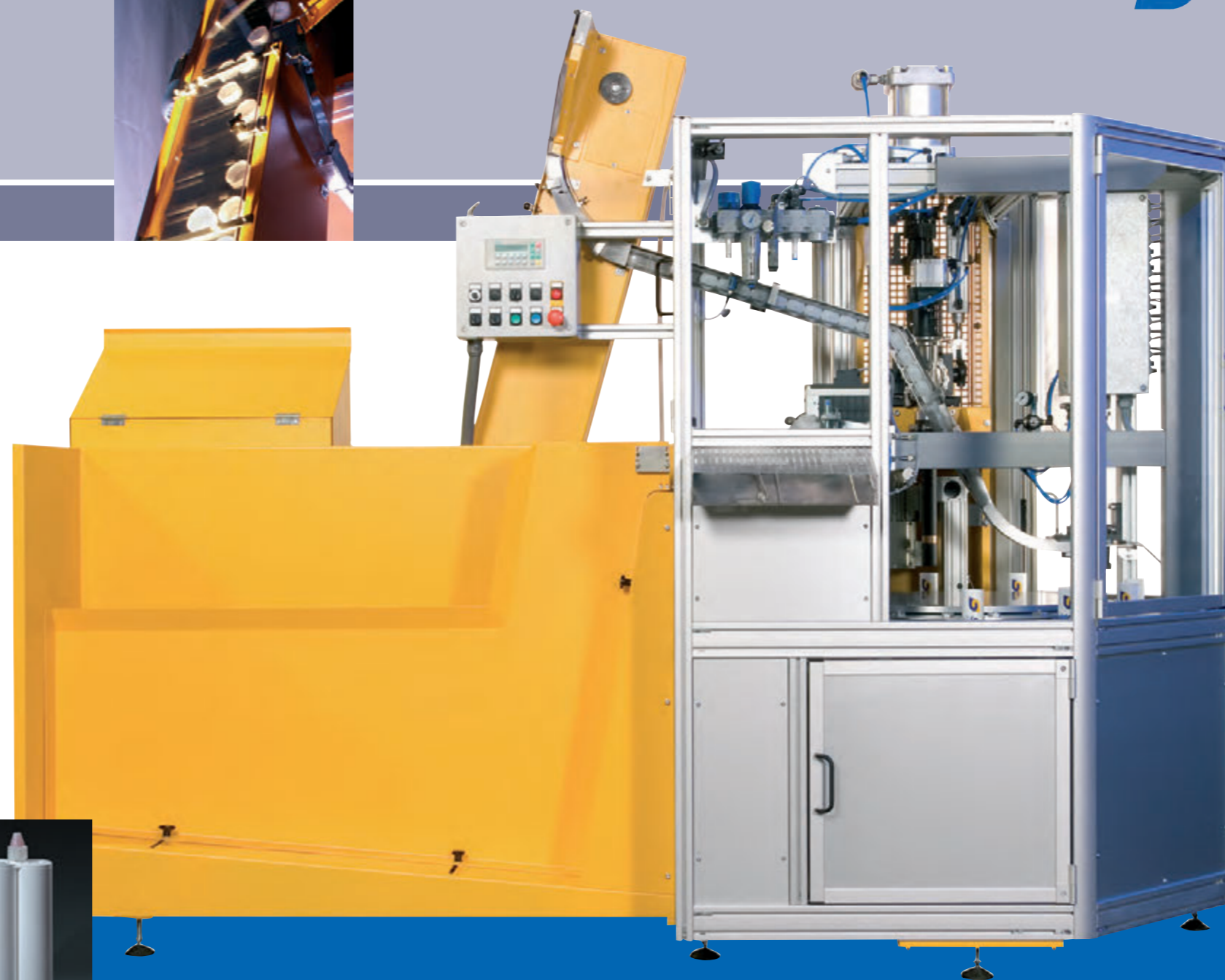

Technology:

The **S 8-V** can fill single and two-component cartridges of various sizes fully automatically, whether made from plastic, compound material or aluminium. Due to the vertical filling concept it is possible to fill from low-viscosity up to extremely high-viscosity products without affecting the quality.

Here, too, we certainly stick to our long since proven **Schwerdtel components**:

- filling of cartridges without air inclusions
- product cut-off at the end of the dosing
- inserting of plungers without air inclusions by means of a venting wires or a special designed plunger housing

The optimized design allows the set of product-contacted parts to be changed in a maximum of 10 minutes. Exemplarily safety equipments - conform with CE standard - guarantee an optimal protection for operator and machine.

Your advantages are obvious:

- high output and flexibility
- solutions for non-standard cartridges and niche products
- high-precision dosing
- quick change of product-contacted parts
- high machine availability
- proven **Schwerdtel service**, especially due to a worldwide express supply with spare parts

Non-standard solutions for your requirements:

Besides the filling of low-viscosity products the development of this type of machines was directed to find solutions for non-standard requirements like the usage of cartridges with huge differences in volume (e.g. 100 ml and 310 ml cartridges to be run onto the same machine), two-component cartridges (side-by-side or co-axial cartridges) as well as cartridges made of plastic, compound material or aluminium.

There is no doubt that our vertical fillers can also be combined with our proven multi-component dosing units, which catalyzes and pigments your product directly before the filling procedure.

For Schwerdtel the customer's benefit has top priority:

- high machine availability
- "first aid" at our service hotline: +49 (0) 81 31/90 06-49
- excellent supply with spare parts (parts ordered before 12 a.m. will be delivered at the same day)
- highest quality
- non-standard solutions for complex requirements